

PSY 511 2018-08-22 Course Intro

Rick Gilmore

2018-08-22 08:18:50

Prelude

"If understanding everything we need to know about the brain is a mile, how far have we walked?"

PSY 511

Foundations of Cognitive and Affective Neuroscience

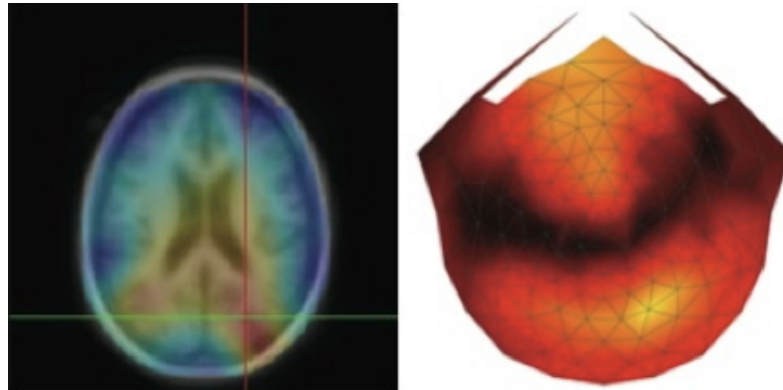

Rick O. Gilmore, Ph.D.
Associate Professor of Psychology

Today's topics

- Why neuroscience is harder than physics
- Course overview
- Methods in neuroscience

Why neuroscience is harder than
physics

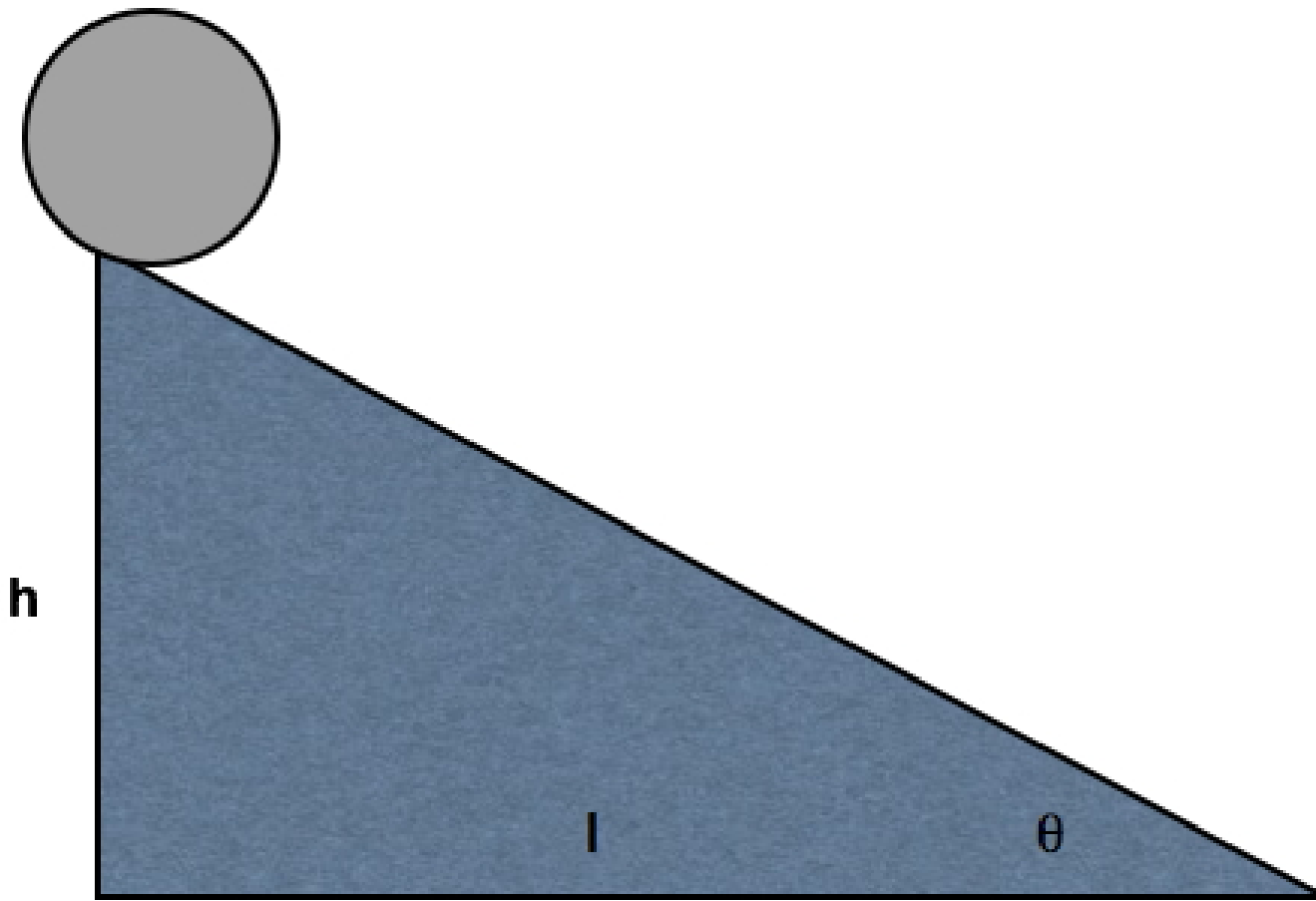

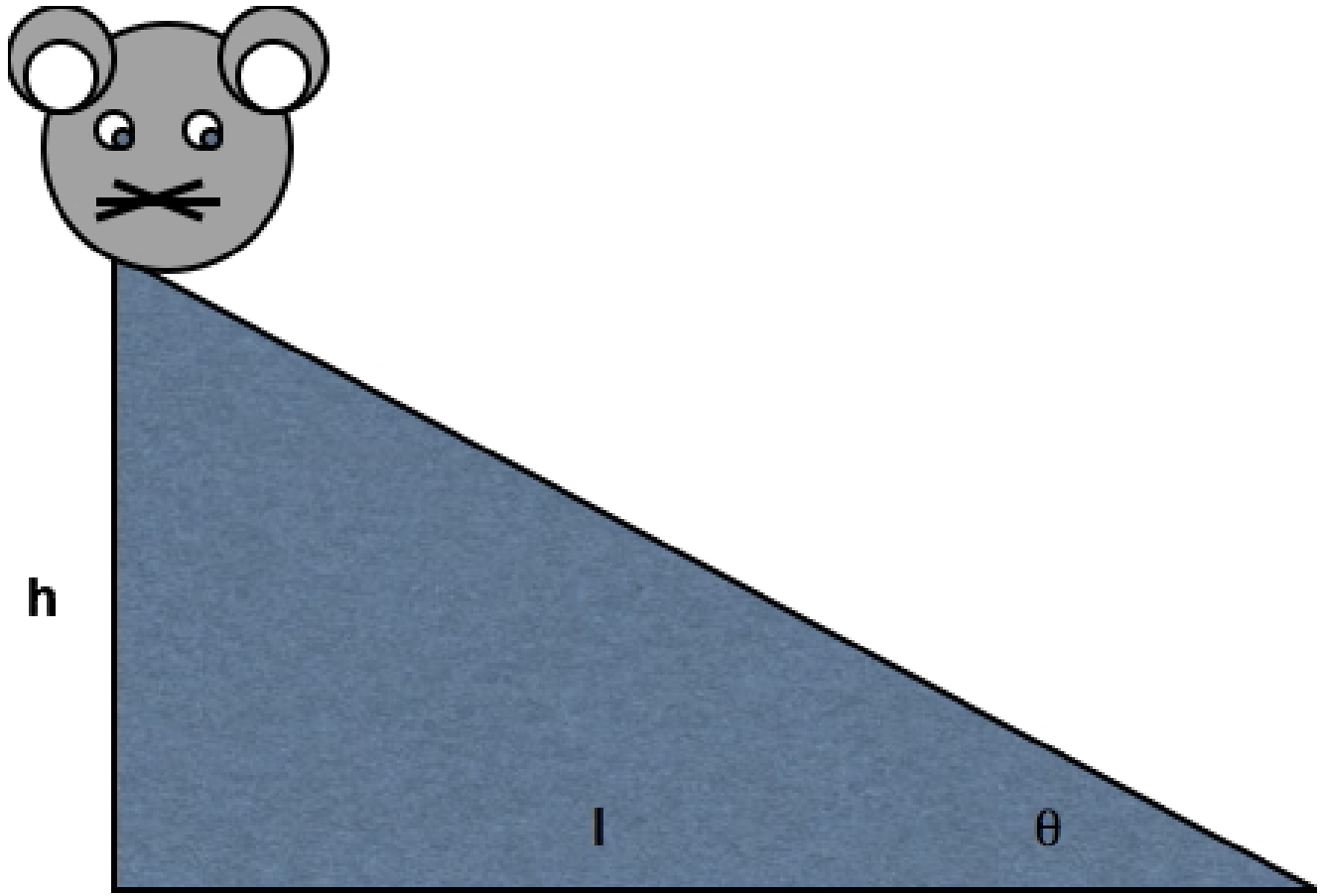

What do we need to know to answer the question?

- What is the state...
 - Of the world
 - Of the organism
 - Body
 - Brain/mind
- Some states more easily measured than others

Brain & behavior are complex, dynamic *systems* with

- Components
- Interactions
- Forces/influences
- Boundaries
- Inputs/outputs/processes

Systems...

- "Behave" or change state across time
- Return to starting state
- Appear to be regulated, controlled, influenced by feedback loops

May be thought of as networks

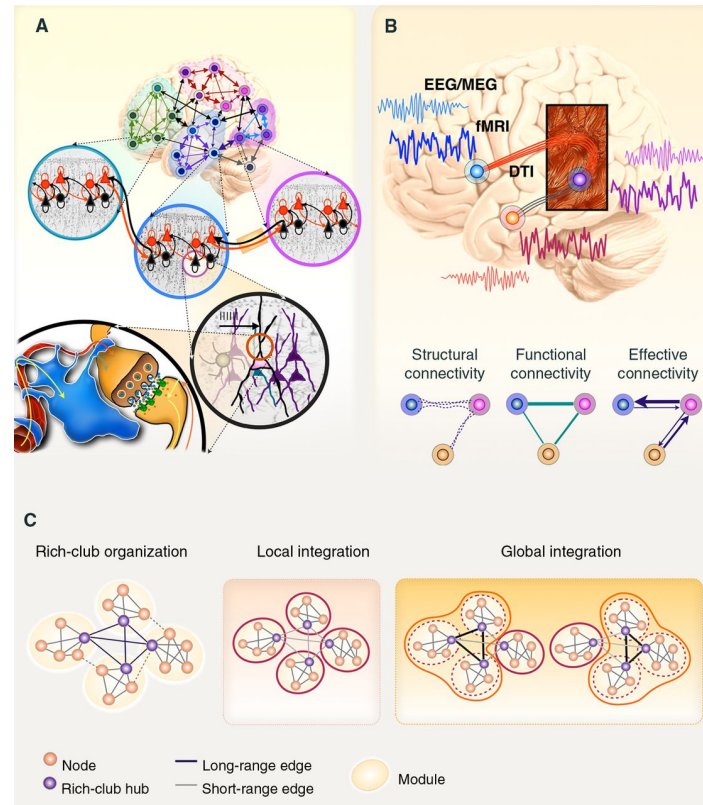

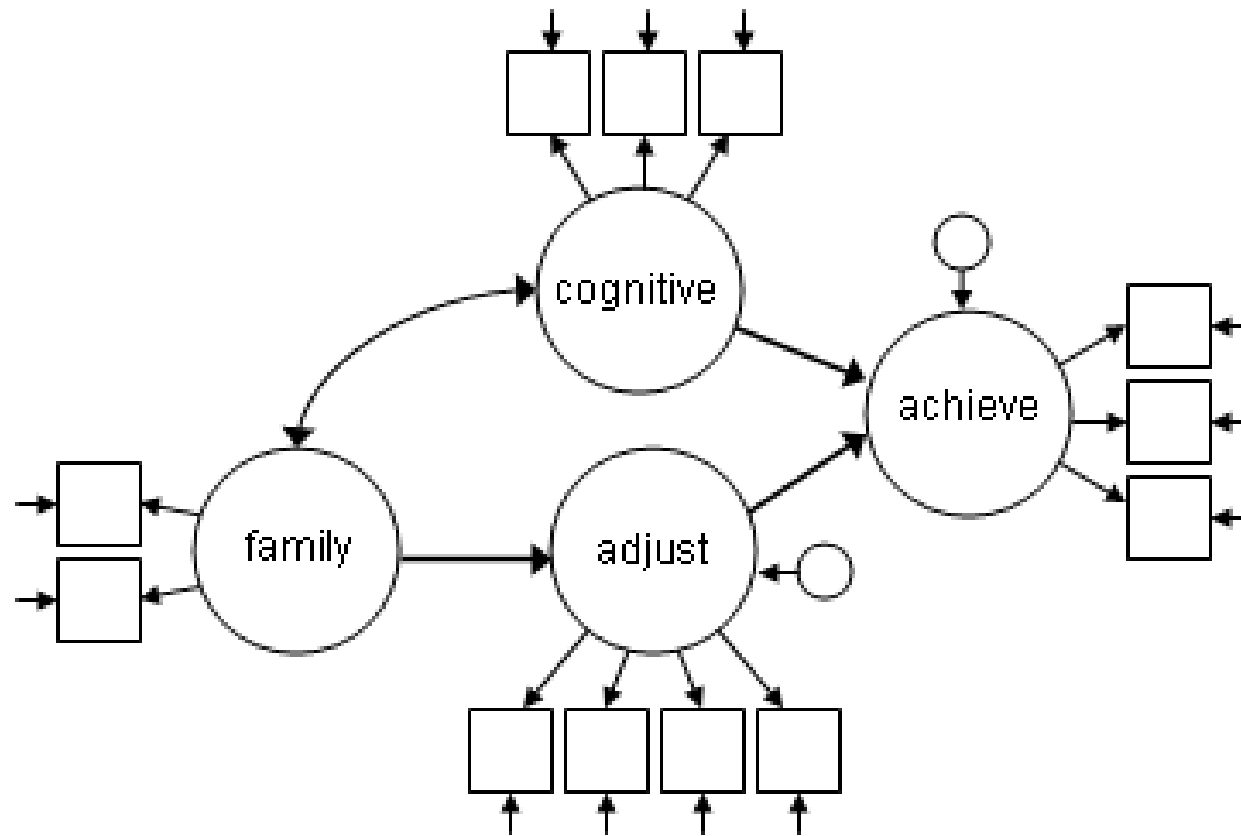

Studying systems is hard because...

- Single parts -> multiple functions
- Single functions -> multiple parts

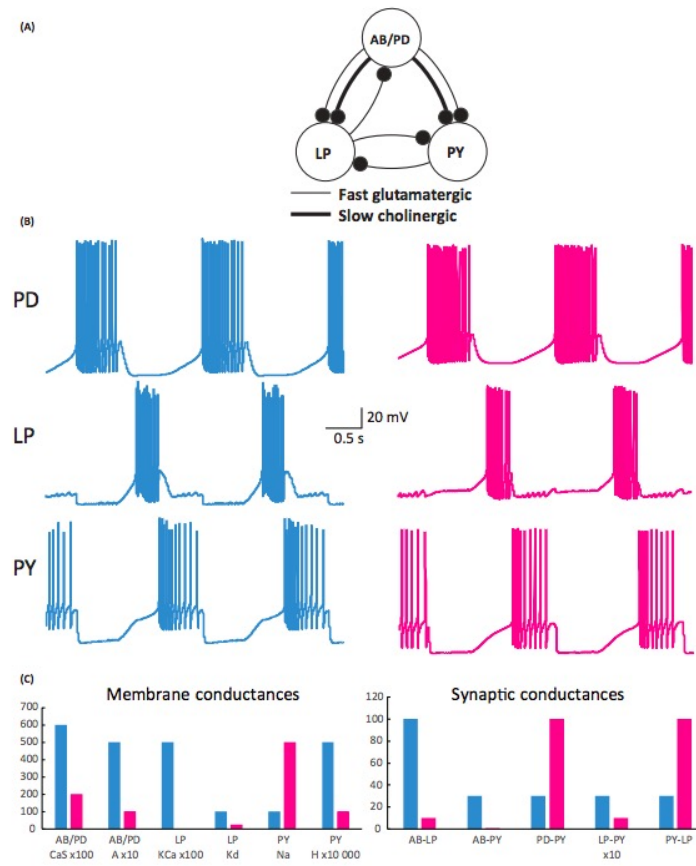

(Calabrese, 2018)

Studying systems is hard because...

- Change structure/function over time
- Biological systems not "designed" like human-engineered ones
- Hard to measure what is being exchanged, what is being controlled

Course overview

PSY 511.001 Goals

- Master fundamentals of neuroscientific concepts and facts
- Prepare to read primary source literature in behavioral, cognitive, affective, and clinical neuroscience

Structure

<https://psu-psychology.github.io/psy-511-scan-fdns-2018>

Questions

- What is the basic plan of the nervous system?
- How do neurons work?
- How do neurons connected in networks achieve behavioral goals?
- How does the nervous system develop? How has it evolved?
- How do disorders of the mind reveal themselves in the nervous system?

Approach

Brain architecture (neuroanatomy)

Brain function (neurophysiology)

Brain communication (neurochemistry)

Changes over evolutionary and developmental time

Approach

The nervous system as information processing system

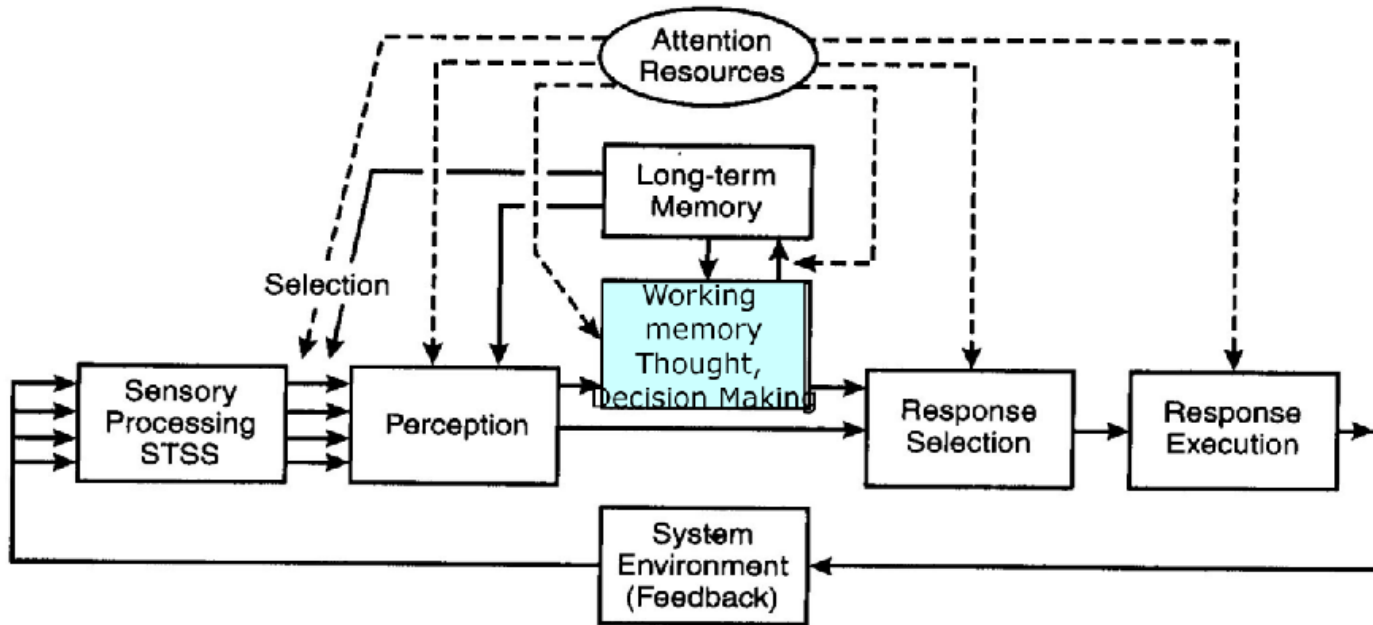

Figure 1.3 A model of human information processing stages.

Inputs

- From environment, body, brain

Processing

- Current inputs + brain state + body state + possible future states...
- Stored information
- Physiological & behavioral goals

Outputs

- To brain, body, environment

Cajal/Swanson Architecture

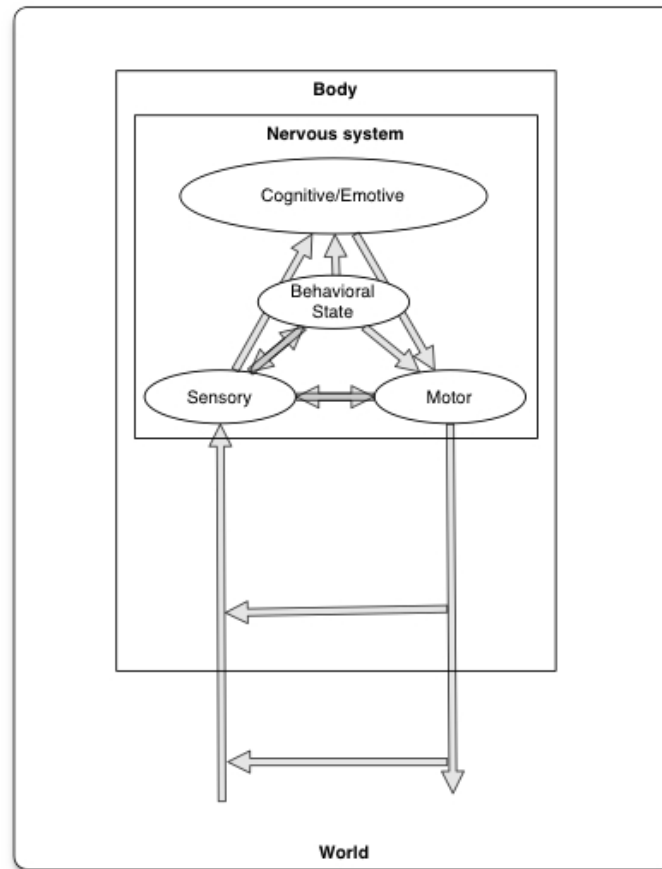

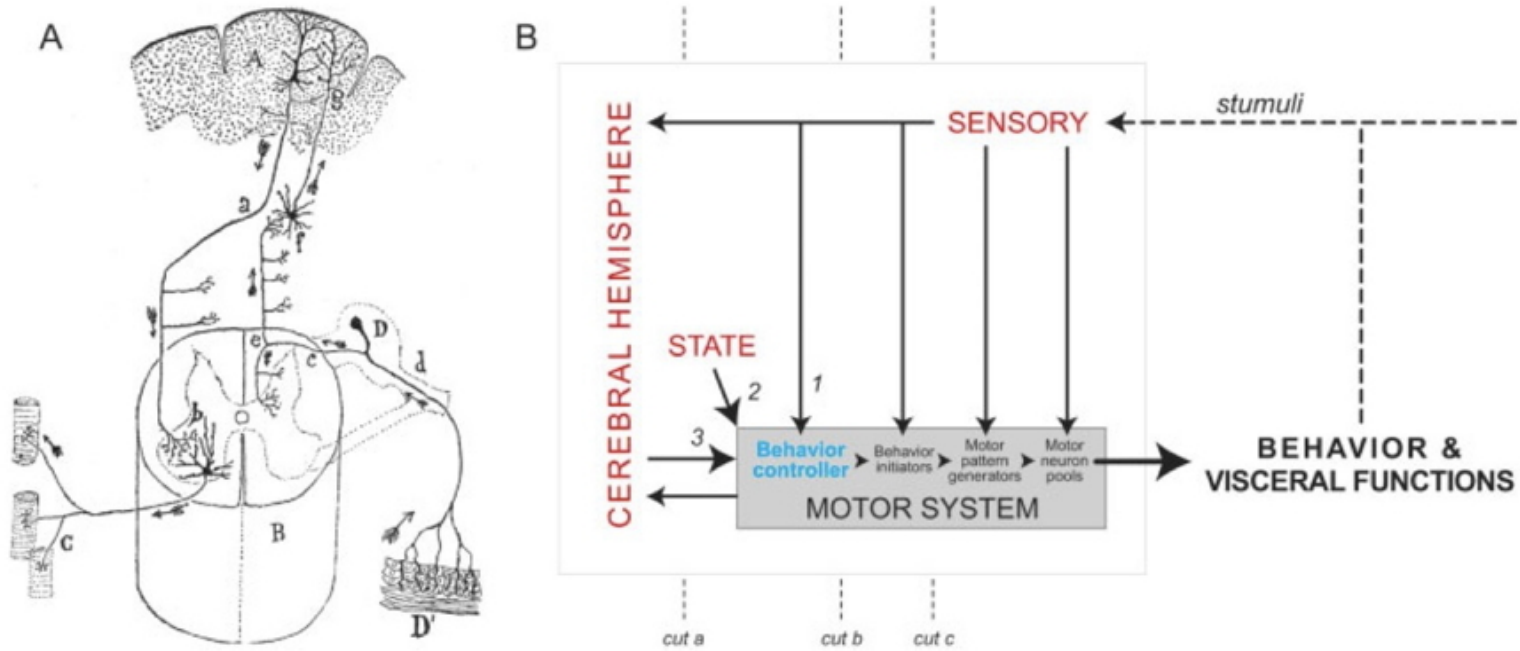

Fig. 1. **A:** Perhaps the first diagram illustrating the cellular organization of a vertebrate spinal reflex, based on the neuron doctrine and law of functional polarity, published by Cajal in 1890 (see Cajal, 1894). Note that he emphasized two interconnected sources of motor neuron (b) control: dorsal root ganglion cells (D) and cerebral cortical pyramidal (or psychomotor) neurons (A). For clarity, he showed sen-

sory input to the right side of the spinal cord, and motor output from the left side. **B:** A modern version of the basic plan of nervous system organization, adding behavioral state inputs (2) to sensory or voluntary (1) and cerebral hemisphere/cognitive or voluntary (3) inputs to the motor system hierarchy; see text for details (adapted from Swanson, 2000a).

Swanson, 2005

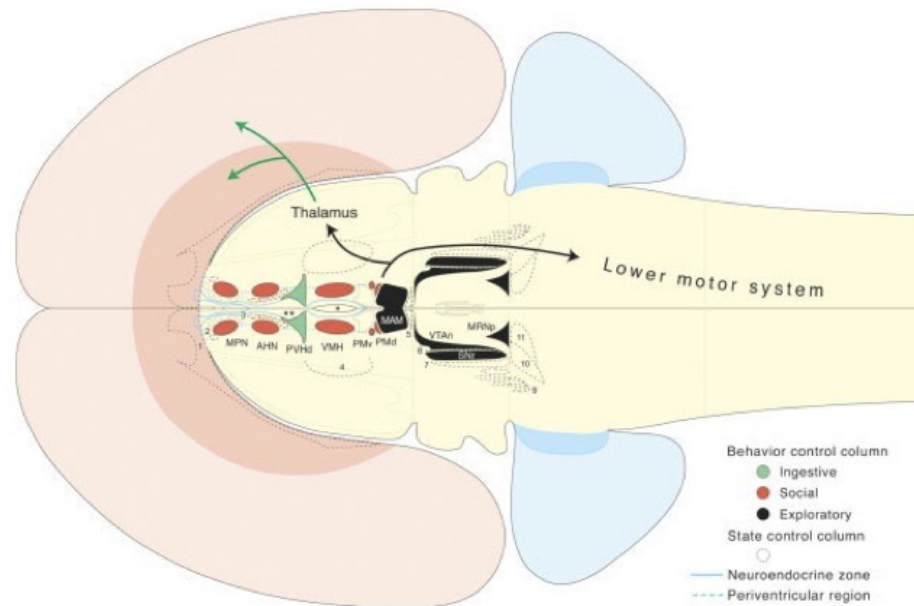

Fig. 3. Basic topography of the behavior control column (BCC) in ventromedial regions of the upper brainstem as viewed on a flatmap of the rat central nervous system. Each component minimally generates a dual projection to the lower motor system (primarily motor pattern generator networks and motoneuron pools) and dorsal thalamus. Where analyzed experimentally (dorsal premammillary nucleus, PMd; mammillary body, MAM; and reticular substantia nigra, SNr), the thalamic projection is a collateral of the descending projection to motor system. This dual projection may be either glutamatergic (e.g., MAM) or GABAergic (e.g., SNr). The BCC caudal segment contains MAM, nondopaminergic ventral tegmental area (VTAn), SNr, and

parvicellular midbrain reticular nucleus (MRNp). The BCC rostral segment contains medial preoptic nucleus (MPN), anterior hypothalamic nucleus (AHN), ventromedial nucleus (VMH), ventral premammillary nucleus (PMv), and PMd. Two critical functional regions lie between the BCC rostral segment and third ventricle (midline): the median eminence (*, asterisk) and surrounding neuroendocrine motor zone (solid blue line), and the periventricular region (dashed blue line and **, double asterisks), which contains visceromotor pattern generator and circadian rhythm generator networks. The behavioral state control column, running parallel to the BCC, is indicated by dashed outlines (see text for more information).

Swanson, 2005

Why neuroscience needs behavior

A

What is done

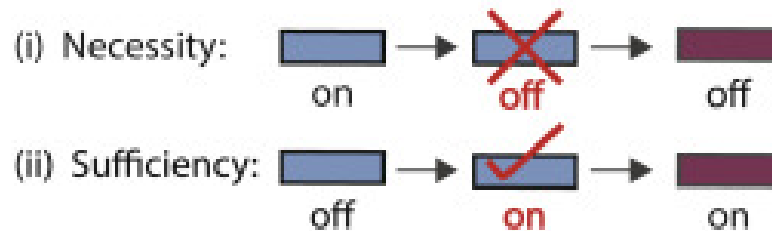

Manipulating a **circuit**
as a way of intervening in **behavior**



B

What is claimed

 is the cause of 

 + "filler" verb = explanation of 

C

Most used "filler" verbs

reflects	encodes
reveals	induces
involves	enables
regulates	ensures
mediates	supports
generates	promotes
modulates	determines
shapes	plays a role in
underlies	contributes to
produces	is associated with

(Krakauer, Ghazanfar, Gomez-Marin, MacIver, & Poeppel, 2017)

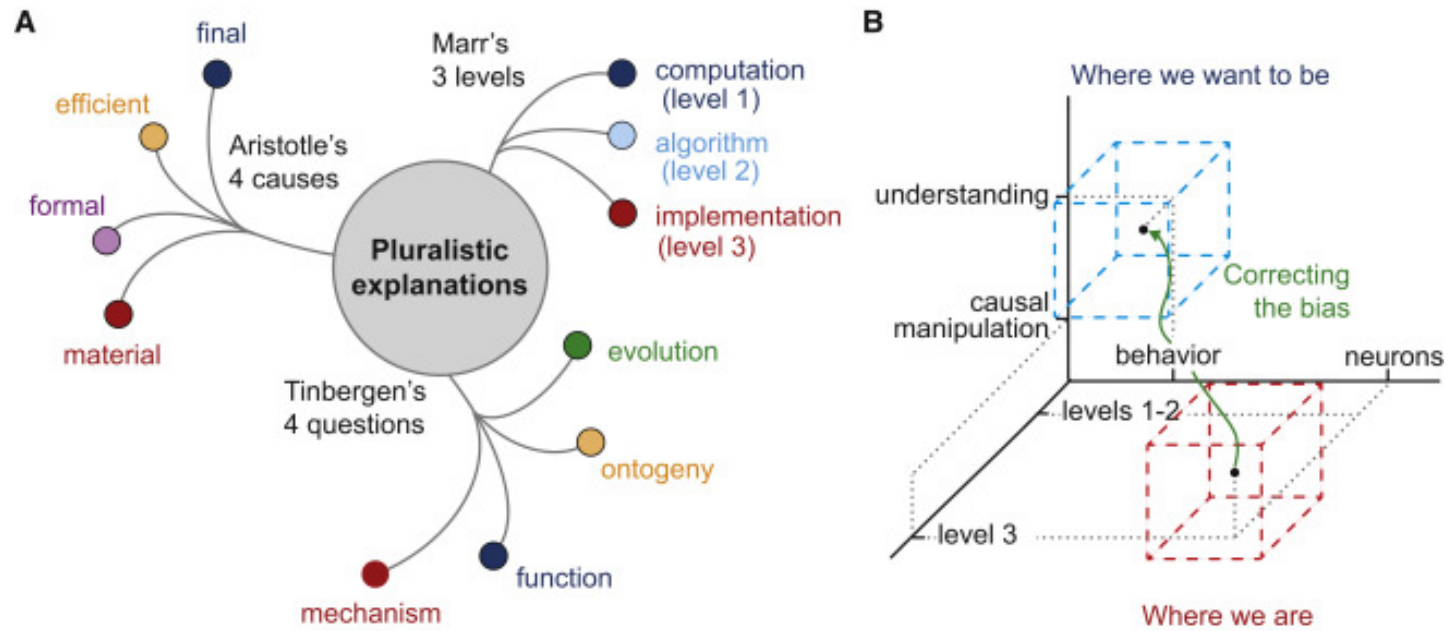

([Krakauer et al., 2017](#))

Neuroscience methods

Evaluating methods

What is the question?

- Structure X \rightarrow Structure Y
- Structure X \rightarrow Function Y

What are we measuring?

- Structure
- Activity
 - Why not *function*?

Evaluating methods

Strengths & Weaknesses

- Cost
- Invasiveness
- Spatial/temporal resolution

Spatial resolution

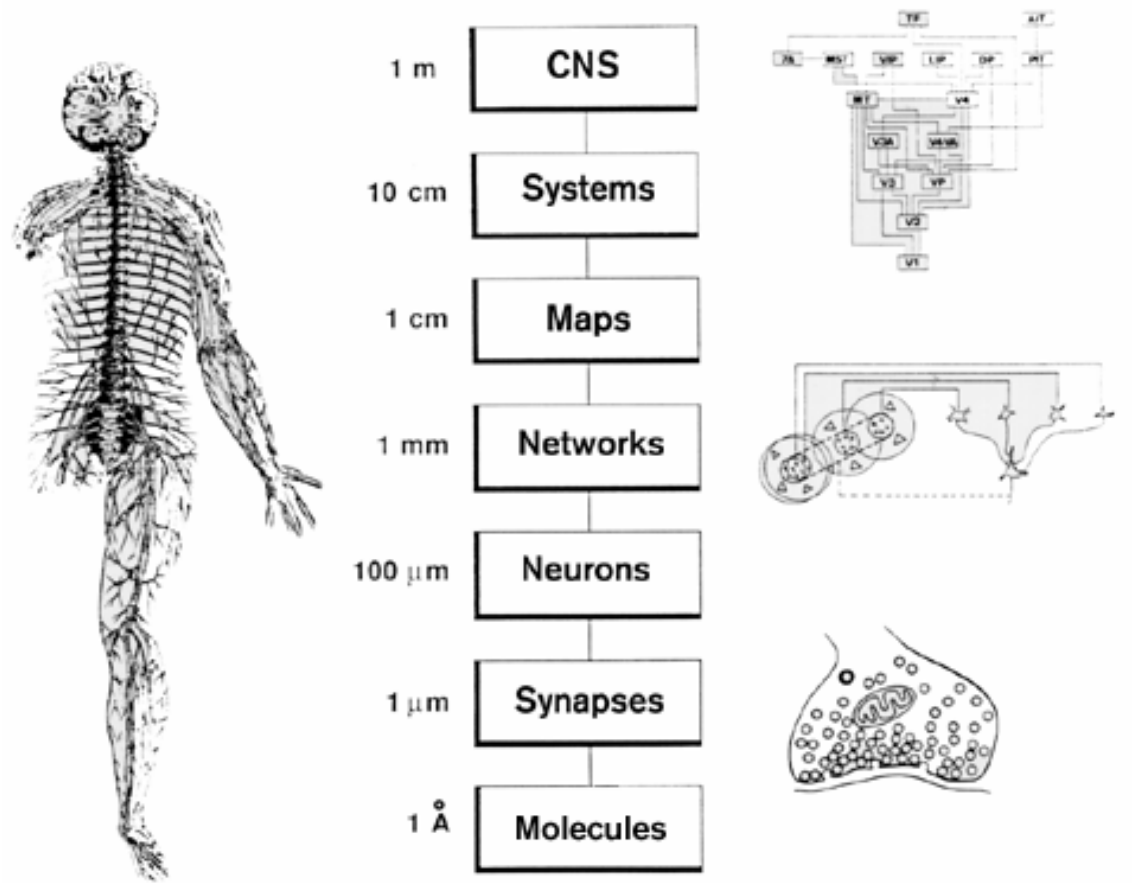

<http://ai.ato.ms/MITECS/Images/churchland.figure1.gif>

...and temporal Resolution

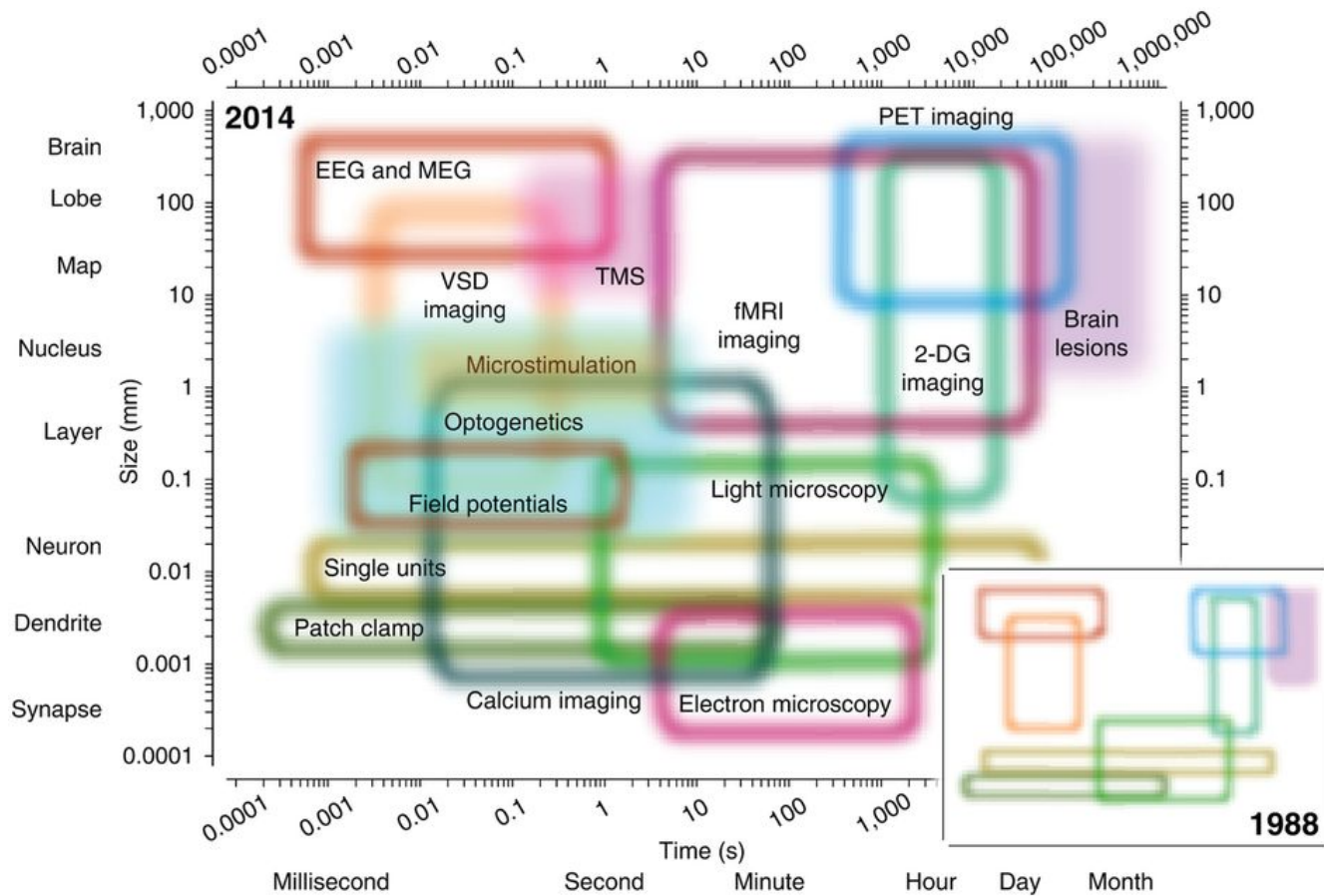

(Sejnowski, Churchland, & Movshon, 2014)

Types of methods

Structural

- Anatomy
- Connectivity/connectome

Functional (next time)

- What does it do?
- Physiology/Activity

Mapping structures

- Cell/axon stains
- **Golgi stain** – whole cells
- Cellular distribution, concentration, microanatomy

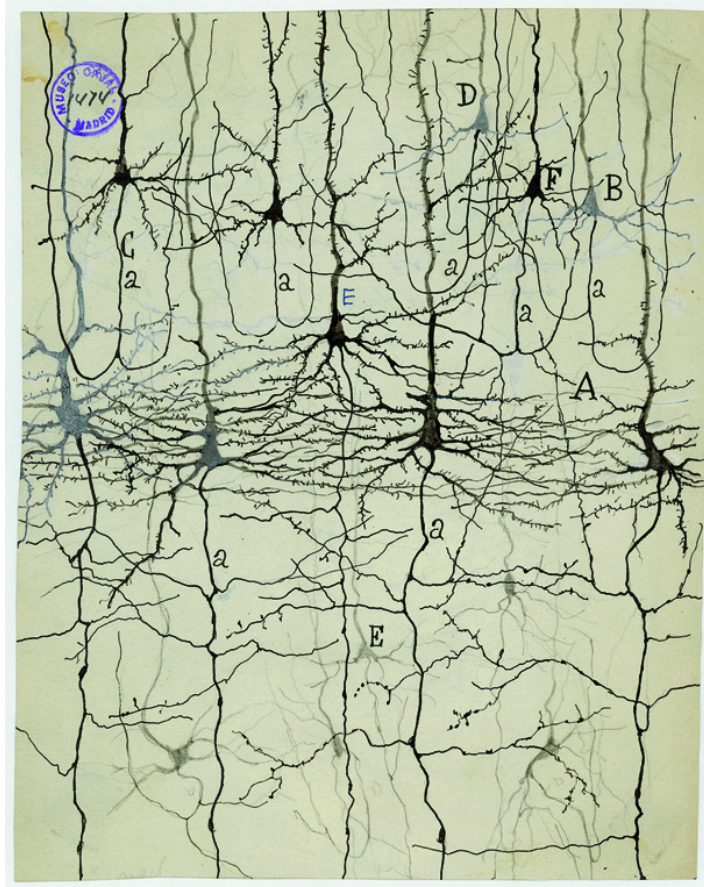

http://connectomethebook.com/wp-content/uploads/2011/11/Brainforest17_1119.jpg



Copyright © Hitobiotec inc.

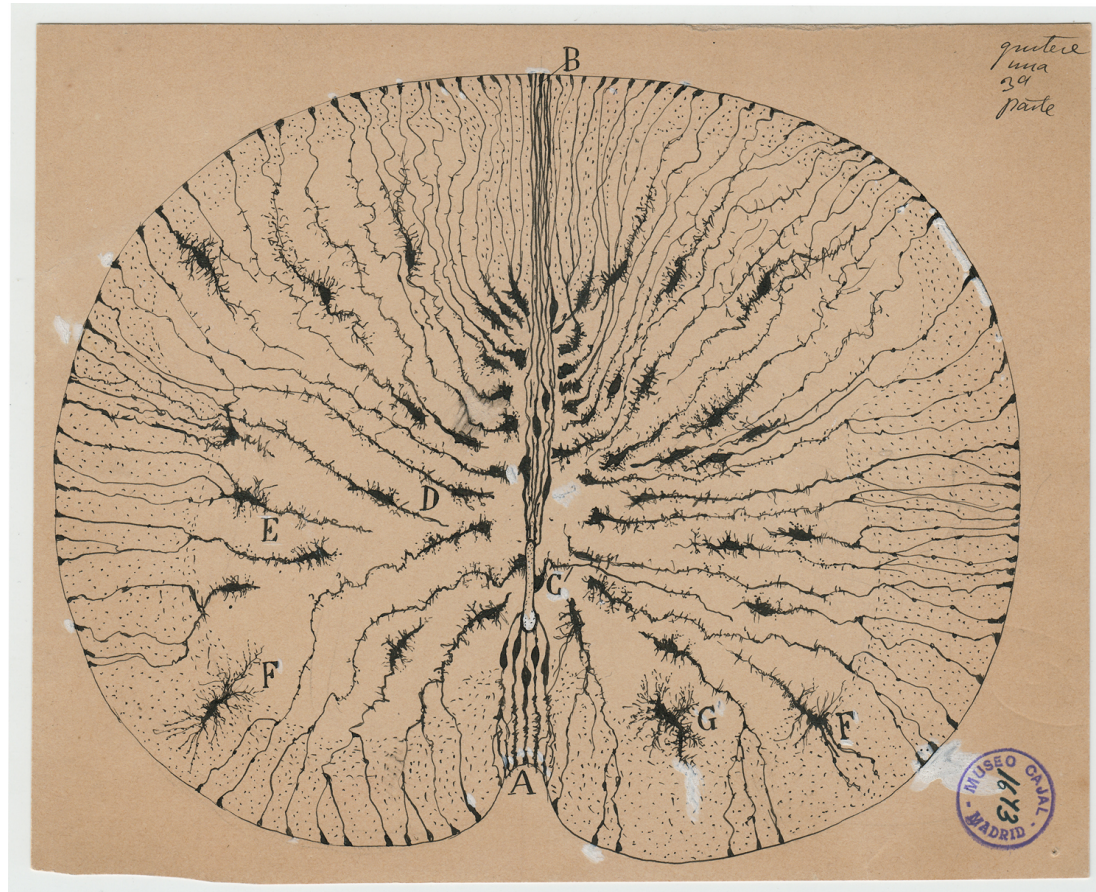

<http://wam.umn.edu/calendar/cajal/>

Camillo Golgi

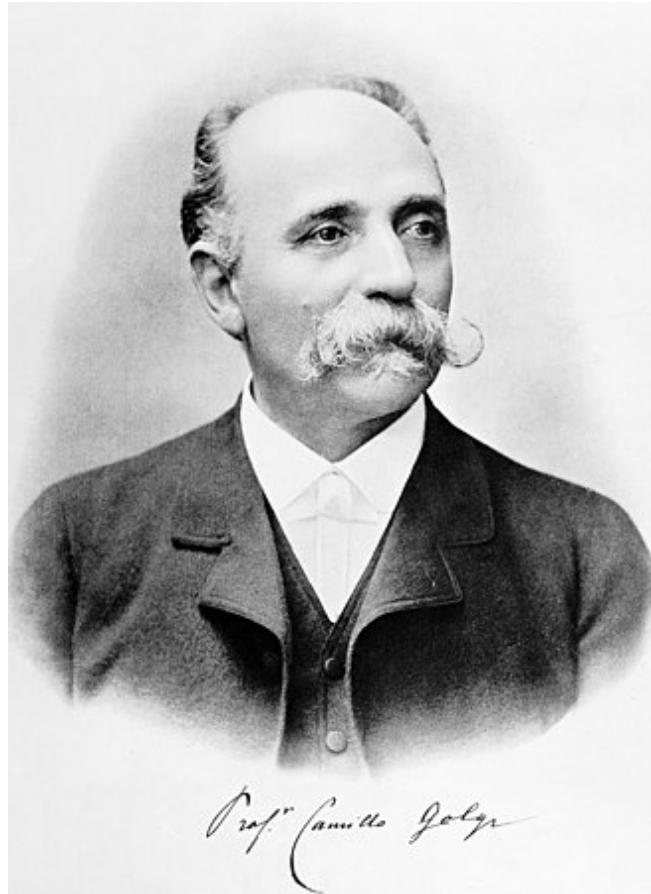

Nissl stain

- Cell bodies

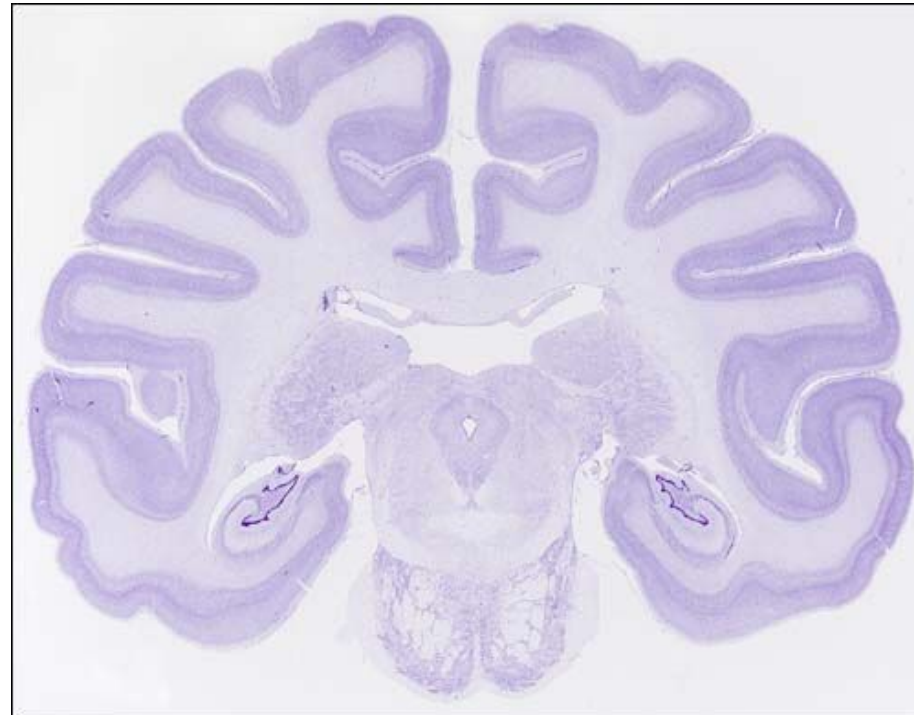

Franz Nissl



Brainbow

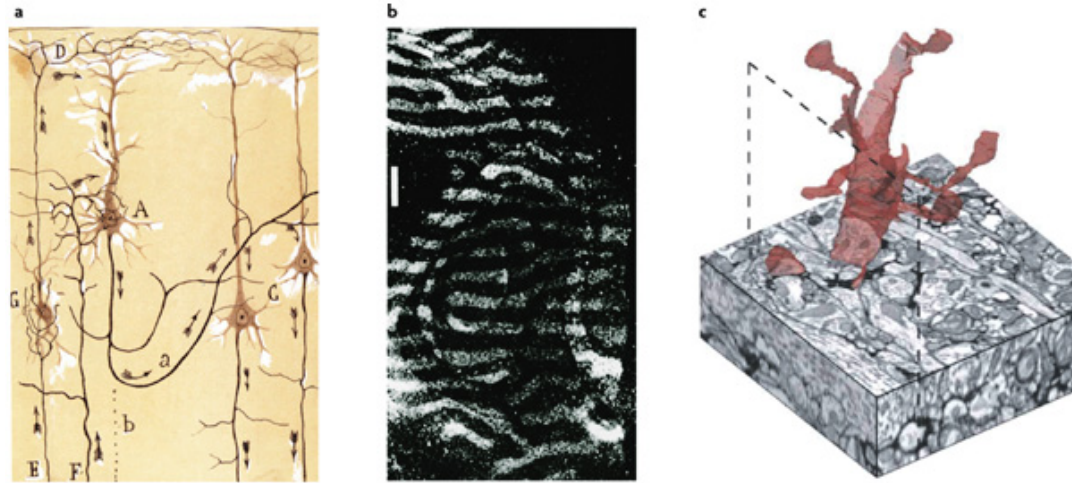

Nature Reviews | Neuroscience

(Lichtman, Livet, & Sanes, 2008)

Brainbow

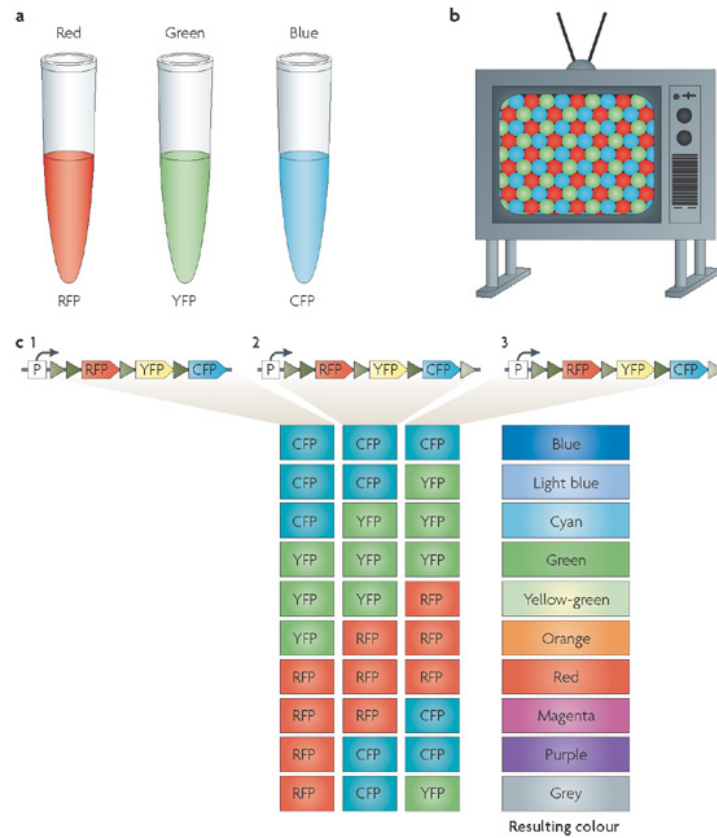

Nature Reviews | Neuroscience

(Lichtman et al., 2008)

Clarity

Evaluating cellular tracing techniques

- Invasive (in humans post-mortem only)
- High spatial resolution, but poor/coarse temporal
 - Why?

Mapping structures

- Computed axial tomography (CAT), CT
- X-ray based

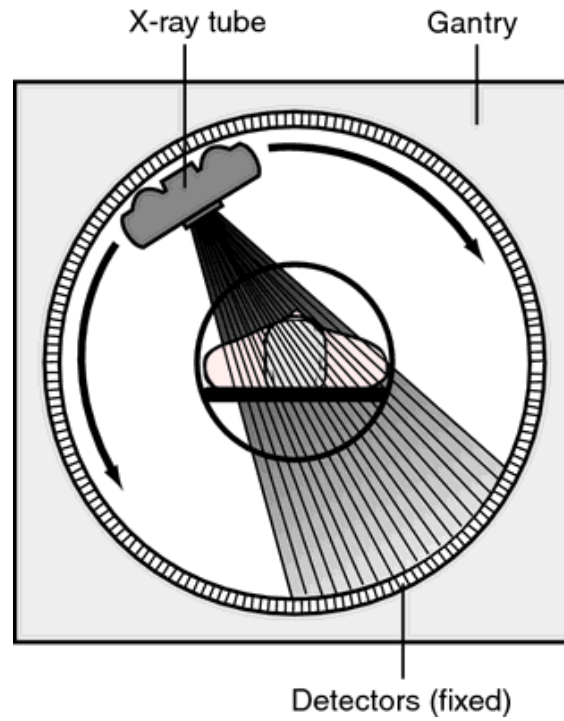

<http://img.tfd.com/mk/T/X2604-T-22.png>

Tomography

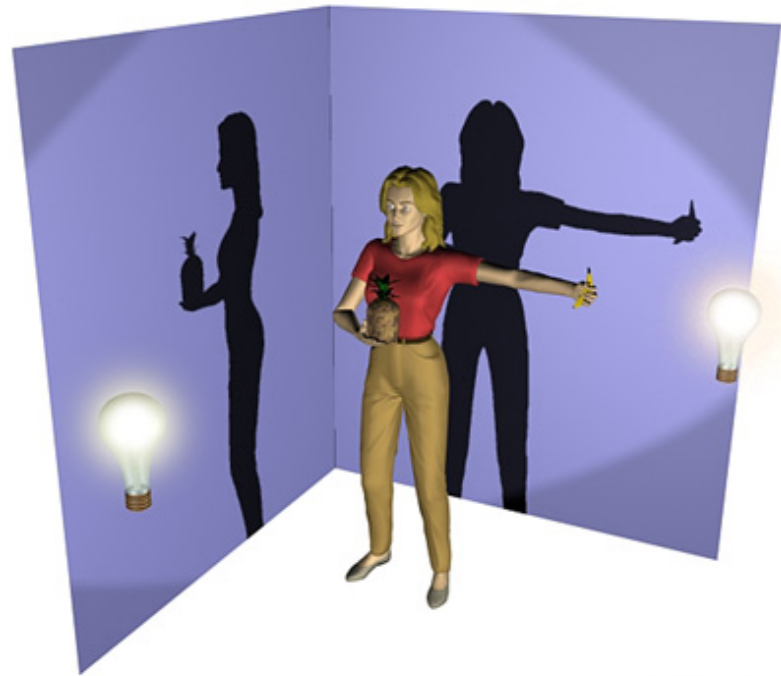

© 2002 HowStuffWorks

<http://static.howstuffworks.com/gif/cat-scan-pineapple.jpg>

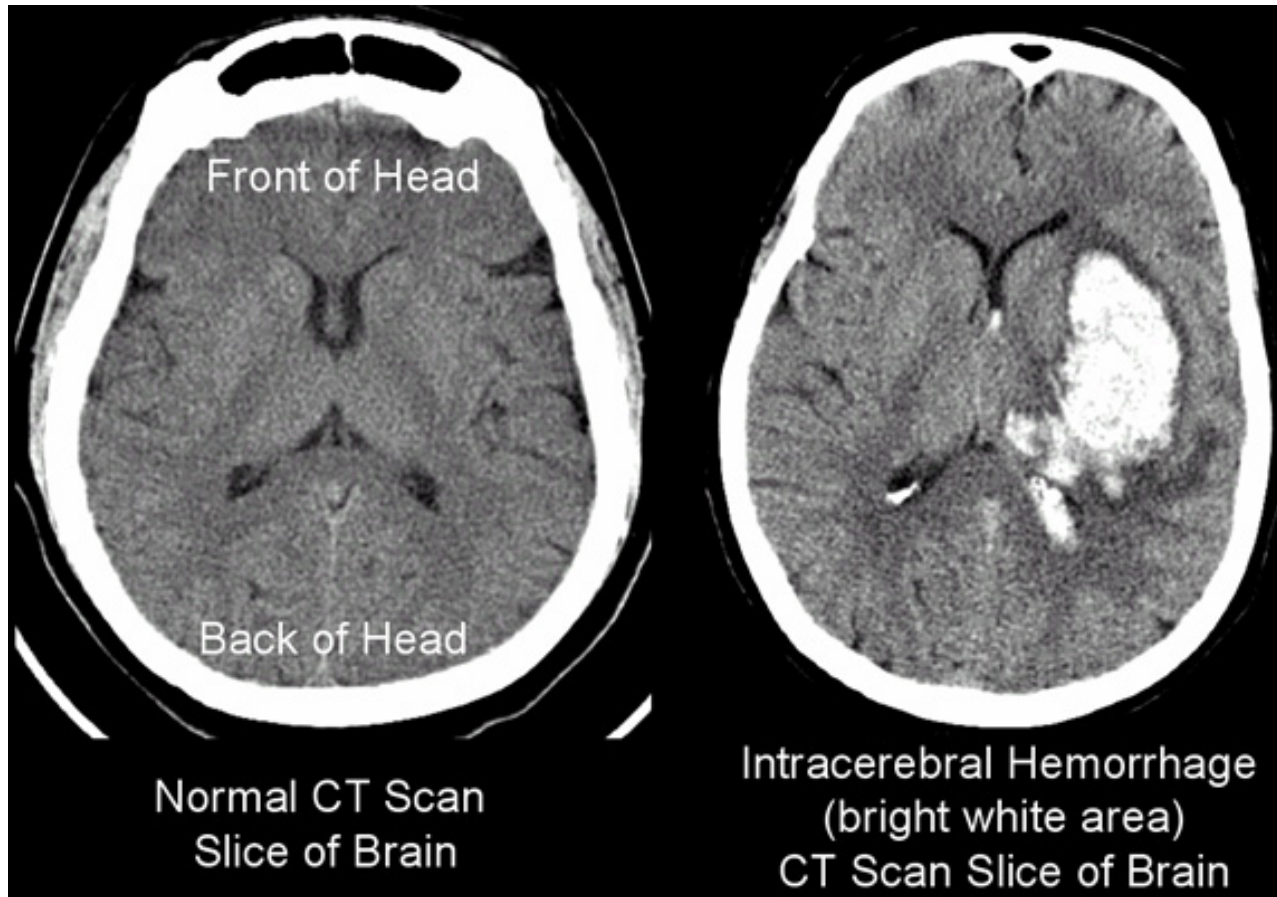

Magnetic Resonance Imaging (MRI)

- Magnetic resonance a property of some isotopes and complex molecules
- Hydrogen (H), common in water & fat, is one
- In magnetic field, H atoms absorb and release radio frequency (RF) energy
- H atoms align with strong magnetic field
- Applying RF pulse perturbs alignment
- Rate/timing of realignment varies by tissue
- Realignment gives off radio frequency (RF) signals
- Strength of RF \sim density

MRI

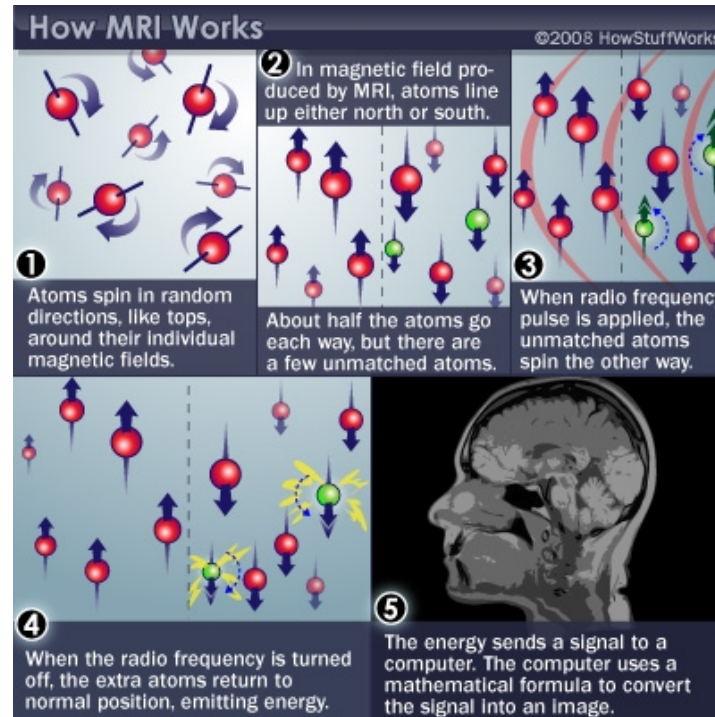

<http://s.hswstatic.com/gif/mri-steps.jpg>

Structural MRI

- Tissue density/type differences
- **Gray matter** (nerve cells & dendrites) vs. **white matter** (axon fibers)
- **Spectroscopy** (specific metabolites)
- Region sizes/volumes



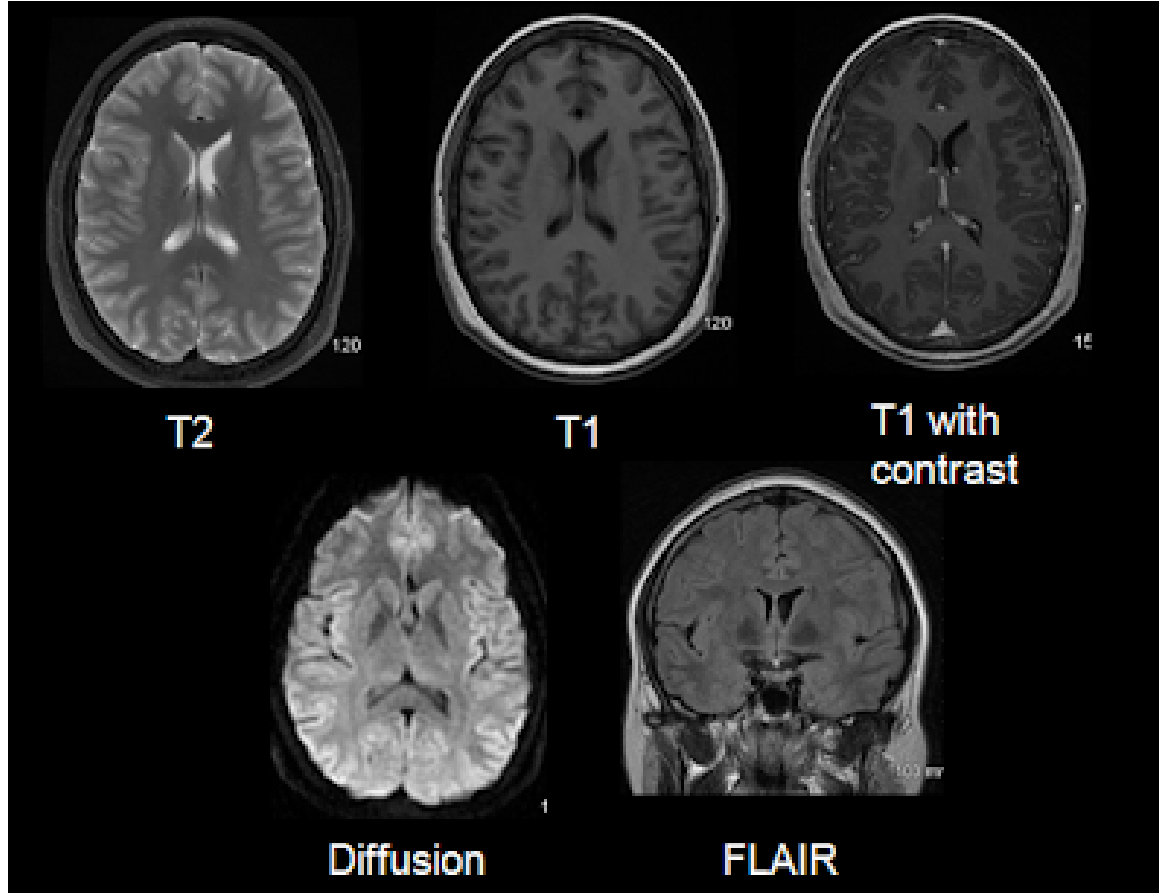

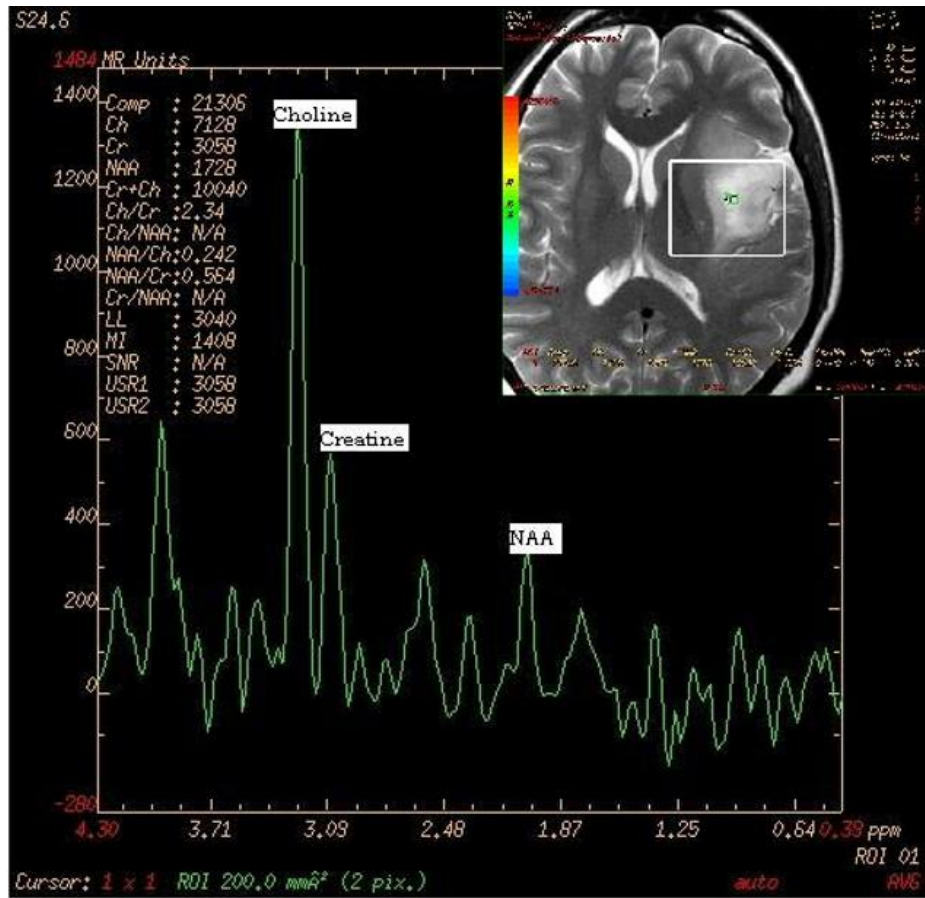

Voxel-based morphometry (VBM)

Volume differences in schizophrenic patients vs. controls

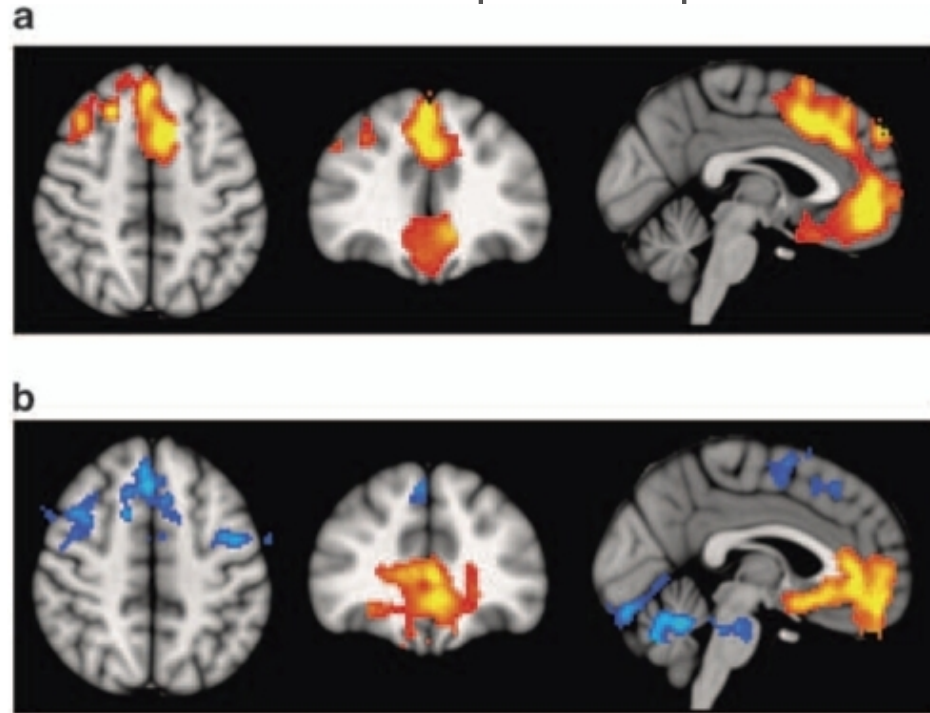

(Pomarol-Clotet et al., 2010)

What is the wiring diagram ("connectome")?

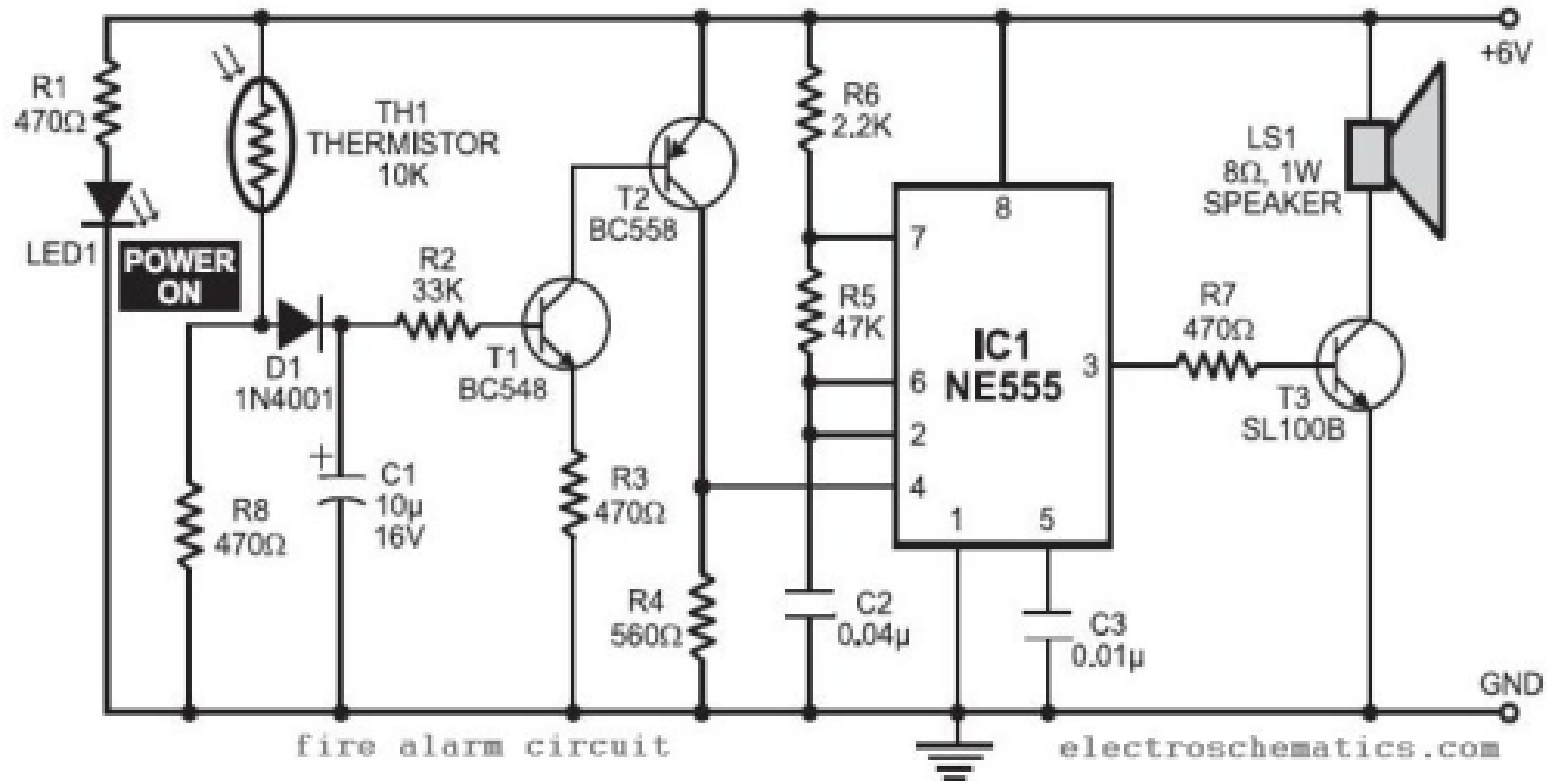

 OPEN ACCESS  PEER-REVIEWED

RESEARCH ARTICLE

Could a Neuroscientist Understand a Microprocessor?

Eric Jonas , Konrad Paul Kording

Published: January 12, 2017 • <https://doi.org/10.1371/journal.pcbi.1005268>

Article



Authors

Metrics

Comments

Related Content

Retrograde (output -> input) vs. anterograde (input -> output) tracers

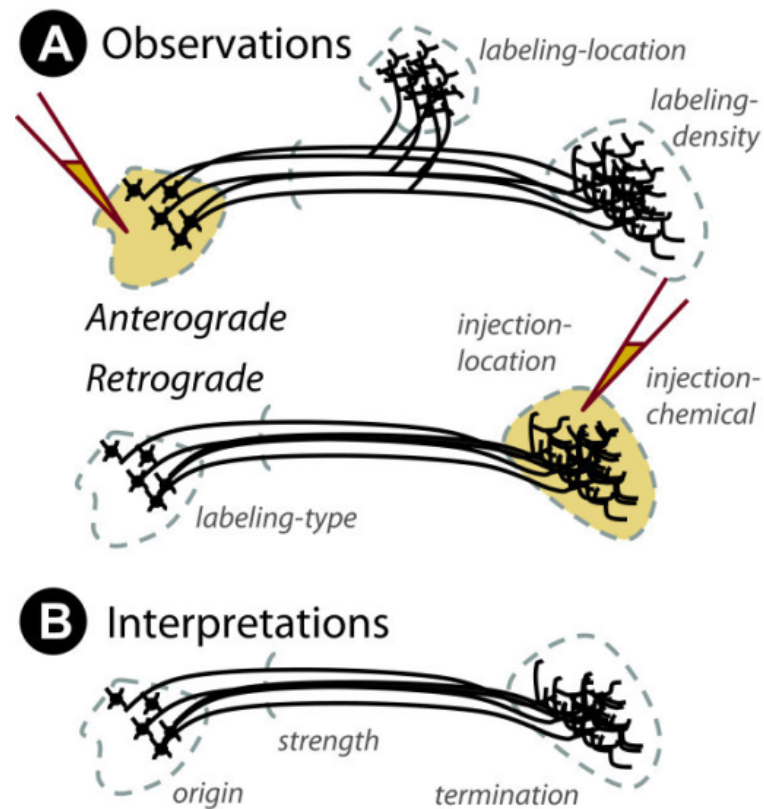

http://openi.nlm.nih.gov/imgs/512/348/3176268/3176268_1471-2105-12-351-2.png

Diffusion Tensor Imaging (DTI)

- Structural MRI technique
- Diffusion tensor: measurement of spatial pattern of H_2O diffusion in small volume
- Uniform ("isotropic") vs. non-uniform ("anisotropic")
- Strong anisotropy suggests large # of axons with similar orientations (fiber tracts)

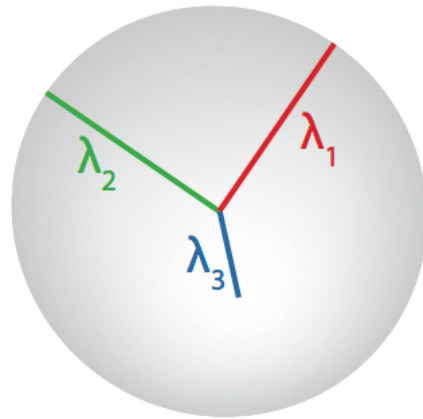

Isotropic

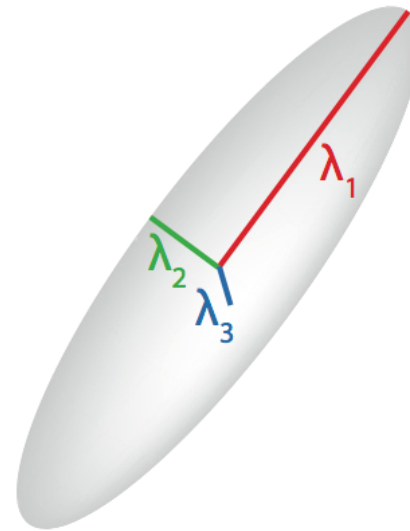

Anisotropic

λ_1 = longitudinal (axial) diffusivity(AD)
 $(\lambda_2 + \lambda_3)/2$ = radial diffusivity (RD)
 $(\lambda_1 + \lambda_2 + \lambda_3)/3$ = mean diffusivity (MD)

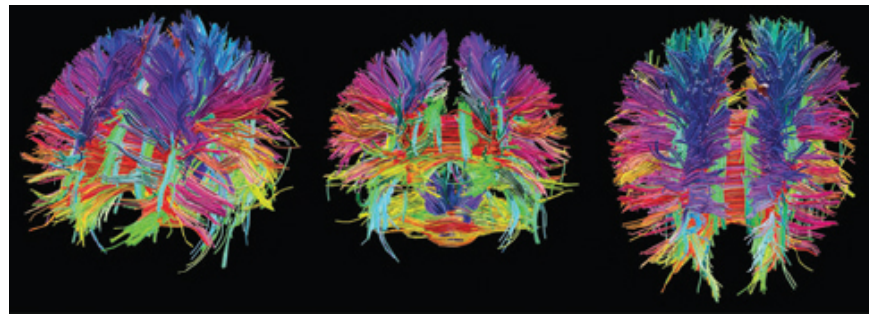
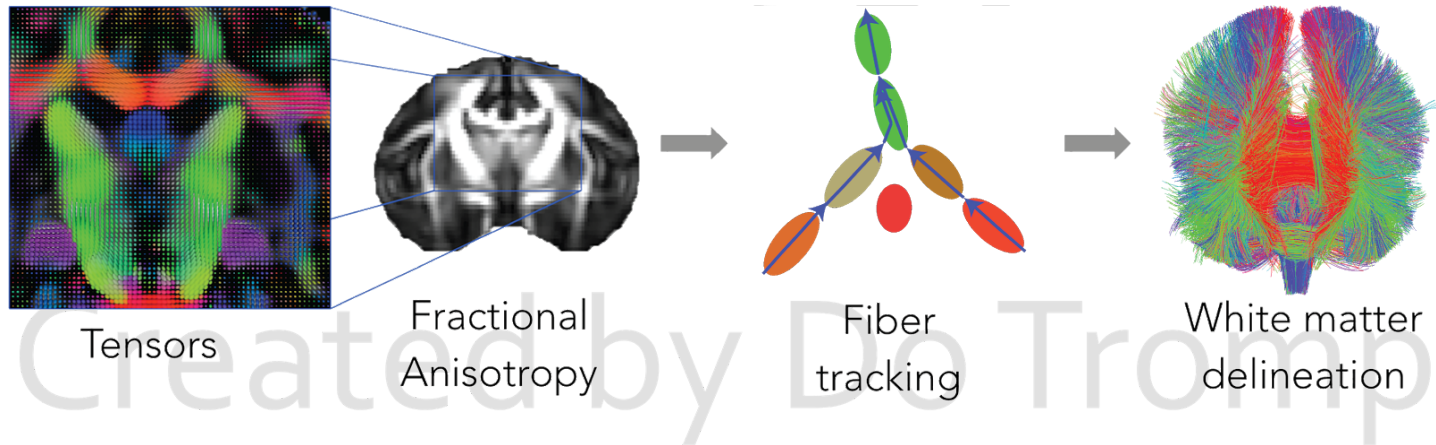

Connectome as matrix

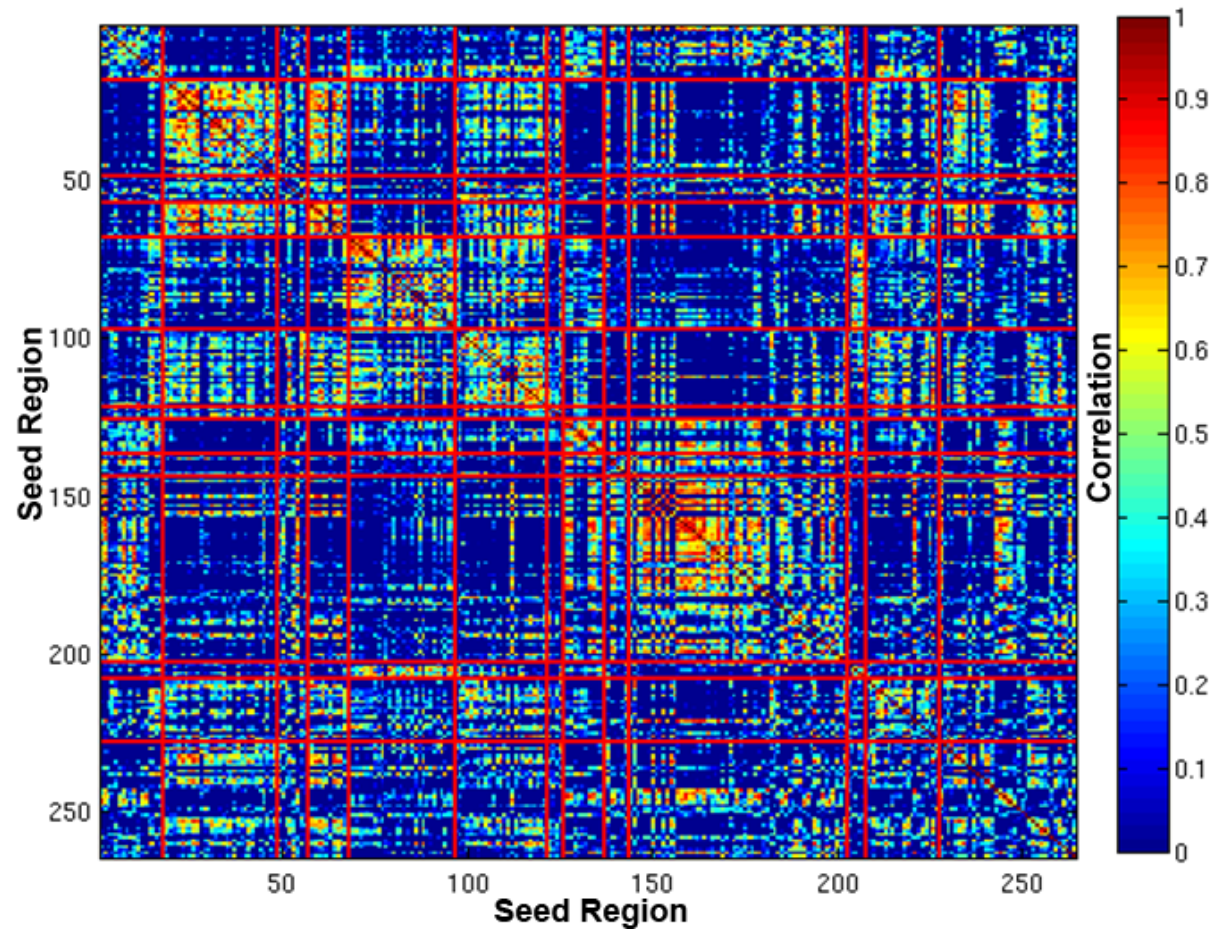

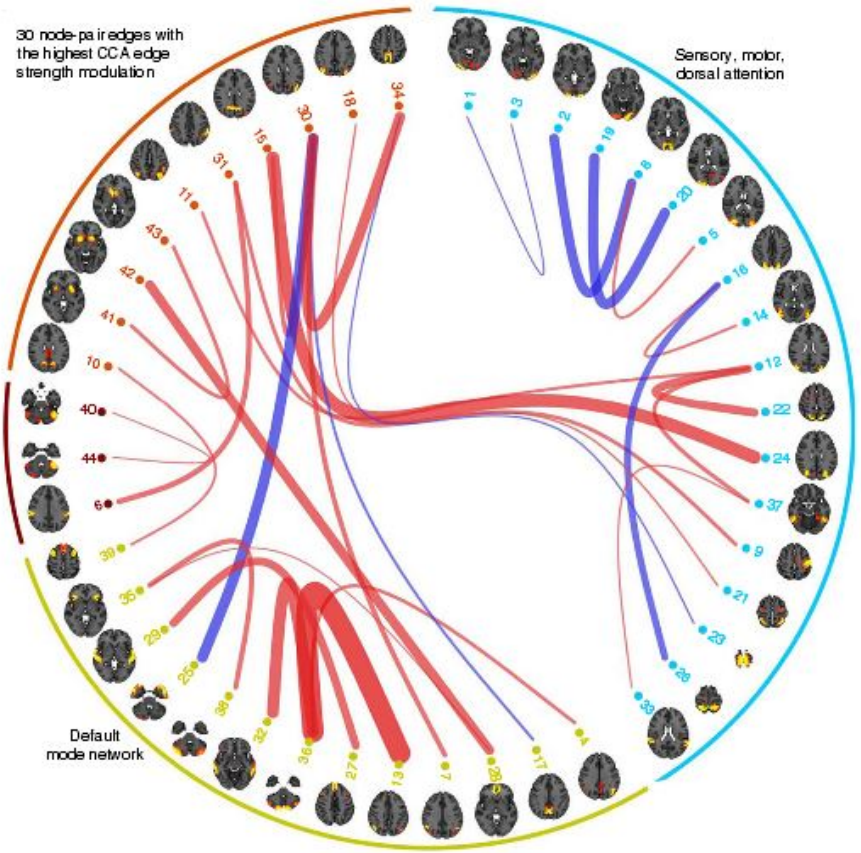

Main points

- Psychology is harder than physics
- Understanding brain/behavior relations requires a diverse toolkit
 - Structural vs. functional methods
 - Spatial and temporal resolution
 - Invasive vs. non-

Your turn

1. Pick two papers you want to read and (better) understand

- Email me APA formatted citation (with DOIs)
- Indicate three concepts/terms you are especially interested in understanding

2. Choose a behavior or mental state you want to (better) understand

- Take an information processing perspective and briefly sketch out (in no more than a short paragraph) the main inputs, outputs, and computations involved.
- When thinking about *outputs* make sure to distinguish between *behaviors* (e.g., movements, facial expressions, vocalizations) and *physiological states* (e.g., changes in heart rate, hormone concentrations in the blood, etc.)

References

Calabrese, R. L. (2018). Inconvenient truth to principle of neuroscience. *Trends in Neurosciences*, 41(8), 488–491. <https://doi.org/10.1016/j.tins.2018.05.006>

Krakauer, J. W., Ghazanfar, A. A., Gomez-Marin, A., Maclver, M. A., & Poeppel, D. (2017). Neuroscience needs behavior: Correcting a reductionist bias. *Neuron*, 93(3), 480–490. <https://doi.org/10.1016/j.neuron.2016.12.041>

Lichtman, J. W., Livet, J., & Sanes, J. R. (2008). A technicolour approach to the connectome. *Nature Reviews Neuroscience*, 9(6), 417–422. <https://doi.org/10.1038/nrn2391>

Pomarol-Clotet, E., Canales-Rodríguez, E. J., Salvador, R., Sarró, S., Gomar, J. J., Vila, F., ... McKenna, P. J. (2010). Medial prefrontal cortex pathology in schizophrenia as revealed by convergent findings from multimodal imaging. *Mol. Psychiatry*, 15(8), 823–830. <https://doi.org/10.1038/mp.2009.146>

Sejnowski, T. J., Churchland, P. S., & Movshon, J. A. (2014). Putting big data to good use in neuroscience. *Nature Neuroscience*, 17(11), 1440–1441. <https://doi.org/10.1038/nn.3839>